



VAF-EF500 - 1.2kW

The Miniveyor Air VAF-EF500 portable exhaust blower packs a big punch, delivering a massive 16,150 m<sup>3</sup> per hour. Also available in 230V/1P, the rugged VAF-EF500 vane axial fan provides maximum airflow when it is needed and is driven by a precision balanced, cast aluminium 9 blade turbo impeller.

The Miniveyor Air VAF-EF500 is designed to push large volumes of air through ducting, enabling the user to get to hard to reach areas.

Motor Rating: IP42                      Noise Rating: 90dB

Body: Non-sparking, heat resistant Lexan® polycarbonate housing with 4-corner handles for fast set-up and storage.

The Blowers should be used in temperatures below 65°C/149°F and the flexible ducting 150°C/302°F

	Air Flow Rating	Power	Current	RPM	Duct Dia.	Size	Weight
VAF-EF500 380V/3P/50Hz	16,150 m <sup>3</sup> /hr 9500 CFM	1.2 kW	18A Start 5A Run		500mm Flange 20 inch Flange	65cm x 63cm x 43cm 25½" x 24¾" x 17"	38 kg 84 lbs

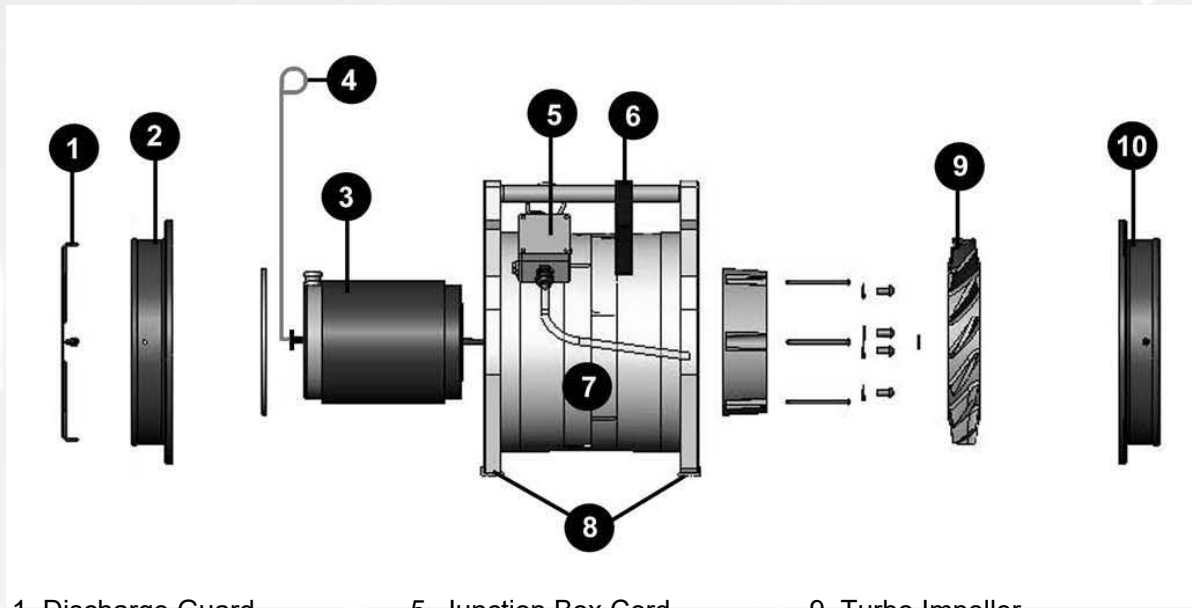

- 1. Discharge Guard
- 2. Duct Adaptor
- 3. Motor
- 4. Switch Rod
- 5. Junction Box Cord
- 6. Handle Cord/Strap
- 7. Housing
- 8. Housing Feet
- 9. Turbo Impeller
- 10. Duct Adaptor



**VAF Air Ltd**

**Worldwide Sales**

VAF Air Ltd  
Unit 4B Tetbury Ind. Est.  
Tetbury, Gloucestershire  
GL8 8EZ  
United Kingdom  
Tel: +44 330 016 0002  
Email: sales@vaf-air.com

**North American Sales**

VAF Air Inc.  
9100 S. Dadeland Blvd  
Suite 1500  
Miami  
Florida 33156 USA  
Tel: 1-855-682-3247  
Email: vafusa@vaf-air.com